

Noise and Frequency Modulation:

Frequency Modulation is much more immune to noise than amplitude modulation and is significantly more immune than phase modulation. In order to establish the reason for this and to determine the extent of the improvement, it is necessary to examine the effect of noise on a carrier.

The effect of noise in FM does not remain constant but it increases with the increase in frequency of mod s/g.

Assuming a single noise frequency, that will also modulate the constant carrier V_c , we get a modulation index due to noise as $\mathbf{M} = \mathbf{V_n/V_o}$.

$$M_{fn} = \delta f_n$$

As modulating s/g frequency increases, modulating index due to mod. s/g decreases.

$$M_{fs} = \delta f_s$$

∴ The s/g to noise ratio in FM.

$$= SN = M_{fs} M_{fn}$$

∴ As $f_s \uparrow$, $M_{fs} \downarrow$ ∴ $S/N \downarrow$

∴ A plot of S/N v/s frequency is not uniform rather a triangle. this is called as Noise Triangle.

Pre-emphasis & De-emphasis is performed to avoid this non-uniform S/N.

Effects of Noise on Carrier—Noise Triangle:

A single Noise and Frequency Modulation will affect the output of a receiver only if it falls within its bandpass. The carrier and noise voltages will mix, and if the difference is audible, it will naturally interfere with the reception of wanted signals. If such a single-noise voltage is considered vectorially, it is seen that the noise vector is superimposed on the carrier, rotating about it with a relative angular velocity $\omega_n - \omega_c$. This is shown in Figure 5-5. The maximum deviation in amplitude from the average value will be V_n , whereas the maximum phase deviation will be $\Phi = \sin^{-1}(V_n/V_c)$.

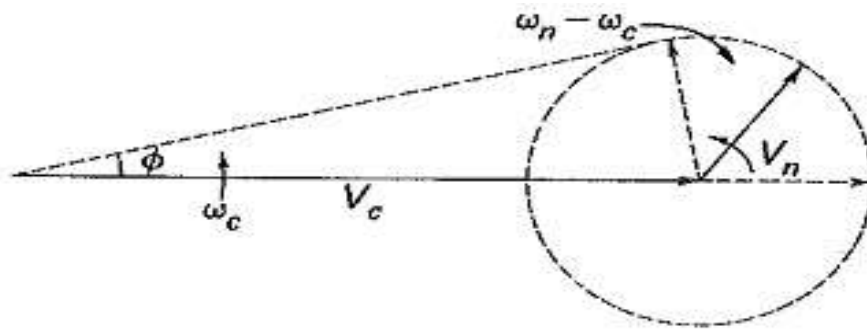

FIGURE 5-5 Vector effect of noise on carrier.

Let the noise voltage amplitude be one-quarter of the carrier voltage amplitude. Then the modulation index for this amplitude modulation by noise will be $m = V_n/V_c = 0.25/1 = 0.25$, and the maximum phase deviation will be $\Phi = \sin^{-1} 0.25/1 = 14.5^\circ$. For voice communication, an AM receiver will not be affected by the phase change. The FM receiver will not be bothered by the amplitude change, which can be removed with an amplitude limiter. It is now time to discuss whether or not the phase change affects the FM receiver more than the amplitude change affects the AM receiver.

The comparison will initially be made under conditions that will prove to be the worst case for FM. Consider that the modulating frequency (by a proper signal, this time) is 15 kHz, and, for convenience, the modulation index for both AM and FM is unity. Under such conditions the relative noise-to-signal ratio in the AM receiver will be $0.25/1 = 0.25$. For FM, we first convert the unity modulation index from radians to degrees ($1 \text{ rad} = 57.3^\circ$) and then calculate the noise-to-signal ratio. Here the ratio is $14.5^\circ/57.3^\circ = 0.253$, just slightly worse than in the AM case.

The effects of Noise and Frequency Modulation change must now be considered. In AM, there is no difference in the relative noise, carrier, and modulating voltage amplitudes, when both the noise difference and modulating frequencies are reduced from 15 kHz to the normal minimum audio frequency of 30 Hz (in high-quality broadcast systems). Changes in the noise and modulating frequency do not affect the signal-to-noise (S/N) ratio in AM. In FM the picture is entirely different. As the ratio of noise to carrier voltage remains constant, so does the value of the modulation index remain constant (i.e., maximum phase deviation). It should be noted that the noise voltage phase-modulates the carrier. While the modulation index due to noise remains constant (as the noise sideband frequency is reduced), the modulation index caused by the signal will go on increasing in proportion to the reduction in frequency. The signal-to-noise ratio in FM goes on reducing with frequency, until it reaches its lowest value when both signal and noise have an audio output frequency of 30 Hz. At this point the signal-to-noise ratio is $0.253 \times 30/15,000 = 0.000505$, a reduction from 25.3 percent at 15 kHz to 0.05 percent at 30 Hz.

Assuming noise frequencies to be evenly spread across the frequency spectrum of the receiver, we can see that noise output from the receiver decreases uniformly with noise sideband frequency for FM. In AM it remains constant. The situation is illustrated in Figure 5-6a. The triangular noise distribution for FM is called the noise triangle. The corresponding AM distribution is of course a rectangle. It might be supposed from the figure that the average voltage improvement for FM under these conditions would be 2:1. Such a supposition might be made by considering the average audio frequency, at which FM noise appears to be relatively half the size of the AM noise. However, the picture is more complex, and in fact the FM improvement is only $\sqrt{3} : 1$ as a voltage ratio. This is a worthwhile improvement—it represents an increase of 3:1 in the (power) signal-to-noise ratio for FM compared with AM. Such a 4.75-dB improvement is certainly worth having.

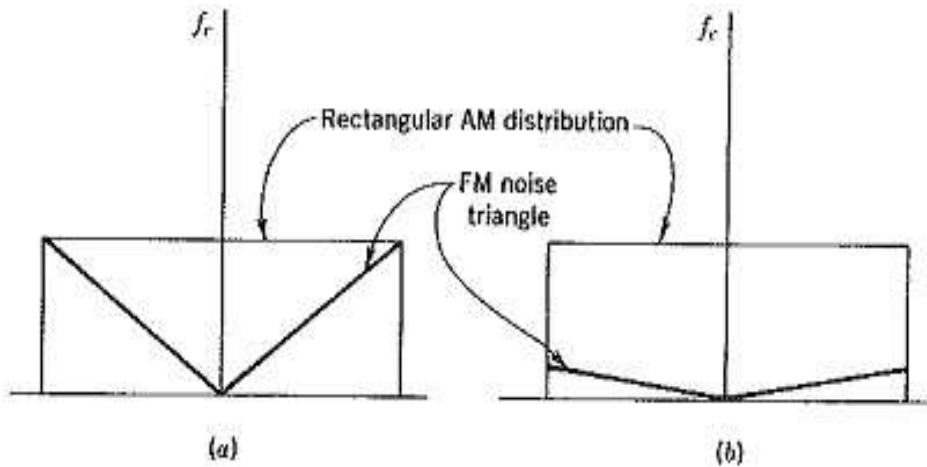

FIGURE 5-6 Noise sideband distribution (noise triangle). (a) $m_f = 1$ at the maximum frequency; (b) $m_f = 5$ at the maximum frequency.

It will be noted that this discussion began with noise voltage that was definitely lower than the signal voltage. This was done on purpose. The amplitude limiter previously mentioned is a device that is actuated by the stronger signal and tends to reject the weaker signal, if two simultaneous signals are received. If peak noise voltages exceeded signal voltages, the signal would be excluded by the limiter. Under conditions of very low signal-to-noise ratio AM is the superior system. The precise value of signal-to-noise ratio at which this becomes apparent depends on the value of the FM modulation index. FM becomes superior to AM at the signal-to-noise ratio level used in the example (voltage ratio = 4, power ratio = 16 = 12 dB) at the amplitude limiter input.

A number of other considerations must now be taken into account. The first of these is that $m = 1$ is the maximum permissible modulation index for AM, whereas in FM there is no such limit. It is the maximum frequency deviation that is limited in FM, to 75 kHz in the wideband VHF

broadcasting service. Thus, even at the highest audio frequency of 15 kHz, the modulation index in FM is permitted to be as high as 5. It may of course be much higher than that at lower audio frequencies. For example, 75 when the modulating frequency is 1 kHz. If a given ratio of signal voltage to noise voltage exists at the output of the FM amplitude limiter when $m = 1$, this ratio will be reduced in proportion to an increase in modulation index. When m is made equal to 2, the ratio of signal voltage to noise voltage at the limiter output in the receiver will be doubled. It will be tripled when $m = 3$, and so on. This ratio is thus proportional to the modulation index, and so the signal-to-noise (power) ratio in the output of an FM receiver is proportional to the square of the modulation index. When $m = 5$ (highest permitted when $f_m = 15$ kHz), there will be a 25 : 1 (14-dB) improvement for FM, whereas no such improvement for AM is possible. Assuming an adequate initial signal-to-noise ratio at the receiver input, an overall improvement of 18.75 dB at the receiver output is shown at this point by wideband FM compared with AM. Figure 5-6b shows the relationship when $m = 5$ is used at the highest frequency.

This leads us to the second consideration, that FM has properties which permit the trading of bandwidth for signal-to-noise ratio, which cannot be done in AM. In connection with this, one fear should be allayed. Just because the deviation (and consequently the system bandwidth) is increased in an FM system, this does not necessarily mean that more random noise will be admitted. This extra random noise has no effect if the noise sideband frequencies lie outside the bandpass of the receiver. From this particular point of view, maximum deviation (and hence bandwidth) may be increased without fear.

Phase modulation also has this property and, in fact, all the noise-immunity properties of FM except the noise triangle. Since noise phase-modulates the carrier (like the signal), there will naturally be no improvement as modulating and noise sideband frequencies are lowered, so that under identical conditions FM will always be 4:75 dB better than PM for noise. This relation explains the preference for Noise and Frequency Modulation in practical transmitters.

Bandwidth and maximum deviation cannot be increased indefinitely, even for FM. When a pulse is applied to a tuned circuit, its peak amplitude is proportional to the square root of the bandwidth of the circuit. If a noise impulse is similarly applied to the tuned circuit in the IF section of an FM receiver (whose bandwidth is unduly large through the use of a very high deviation), a large noise pulse will result. When noise pulses exceed about one-half the carrier size at the amplitude limiter, the limiter fails. When noise pulses exceed carrier amplitude, the limiter goes one better and limits the signal, having been "captured" by noise. The normal maximum deviation permitted, 75 kHz, is a compromise between the two effects described.

It may be shown that under ordinary circumstances ($2V_n < V_c$) impulse noise is reduced in Fm to the same extent as random noise. The amplitude limiter found in AM communications receivers does not limit random noise at all, and it limits impulse noise by only about 10 dB. Noise and Frequency Modulation is better off in this regard also.

Pre-emphasis and De-emphasis:

The noise triangle showed that noise has a greater effect on the higher modulating frequencies than on the lower ones. Thus, if the higher frequencies were artificially boosted at the transmitter and correspondingly cut at the receiver, an improvement in noise immunity could be expected, thereby increasing the signal-to-noise ratio. This boosting of the higher modulating frequencies, in accordance with a prearranged curve, is termed pre-emphasis, and the compensation at the receiver is called de-emphasis. An example of a circuit used for each function is shown in Figure 5-7.



FIGURE 5-7 75-μs emphasis circuits.

Take two modulating signals having the same initial amplitude, with one of them pre-emphasized to twice this amplitude, whereas the other is unaffected (being at a much lower frequency). The receiver will naturally have to de-emphasize the first signal by a factor of 2, to ensure that both signals have the same amplitude in the output of the receiver. Before demodulation, i.e., while susceptible to noise interference, the emphasized signal had twice the deviation it would have had without pre-emphasis and was thus more immune to noise. When this signal is de-emphasized, any noise sideband voltages are de-emphasized with it and therefore have a correspondingly lower amplitude than they would have had without emphasis. Their effect on the output is reduced.

The amount of pre-emphasis in U.S. FM broadcasting, and in the sound transmissions accompanying television, has been standardised as 75 μ s, whereas a number of other services, notably European and Australian broadcasting and TV sound transmission, use 50 μ s. The usage of microseconds for defining emphasis is standard. A 75- μ s de-emphasis corresponds to a frequency response curve that is 3 dB down at the frequency whose time constant RC is 75 μ s. This frequency is given by $f = 1/2 \pi RC$ and is therefore 2120 Hz. With 50- μ s de-emphasis it would be 3180 Hz. Figure 5-8 shows pre-emphasis and de-emphasis curves for a 75- μ s emphasis, as used in the United States.

It is a little more difficult to estimate the benefits of emphasis than it is to evaluate the other FM advantages, but subjective BBC tests with 50 μ s give a figure of about 4.5 dB; American tests have shown an even higher figure with 75 μ s. However, there is a danger that must be considered; the higher modulating frequencies must not be overemphasized. The curves of Figure 5-8 show that a 15-kHz signal is pre-emphasized by about 17 dB; with 50 μ s this figure would have been 12.6 dB. It must be made certain that when such boosting is applied, the resulting signal cannot over-modulate the carrier by exceeding the maximum 75-kHz deviation, since distortion will be introduced. It is seen that a limit for pre-emphasis exists, and any practical value used is always a compromise between protection for high modulating frequencies on the one hand and the risk of over modulation on the other.

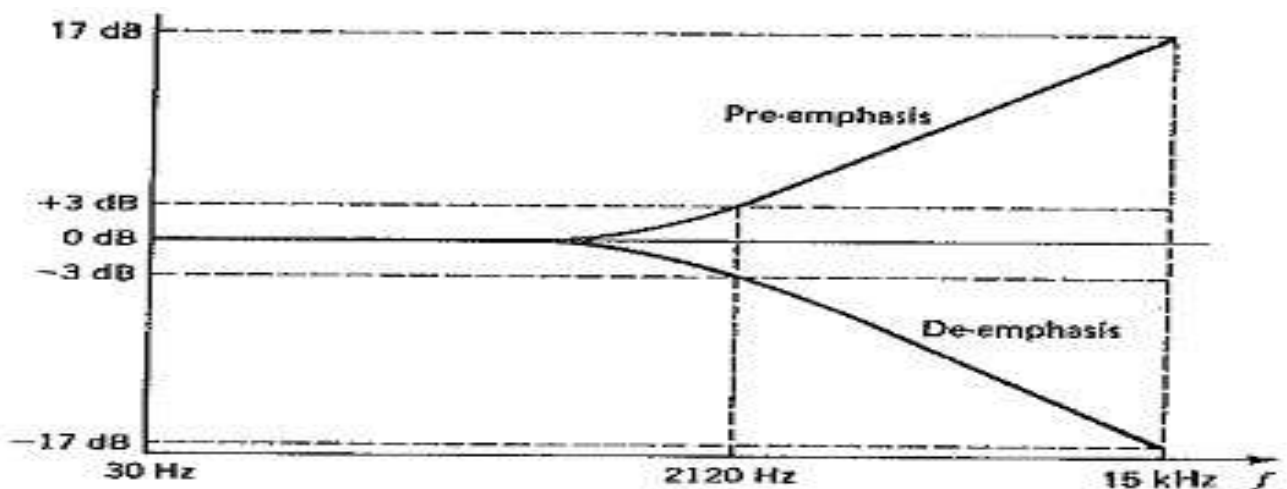

FIGURE 5-8 75- μ s emphasis curves.

If emphasis were applied to amplitude modulation, some improvement would also result, but it is not as great as in FM because the highest modulating frequencies in AM are no more affected by noise than any others. Apart from that, it would be difficult to introduce pre-emphasis and de-emphasis in existing AM services since extensive modifications would be needed, particularly in view of the huge numbers of receivers in use.

Other Forms of Interference:

In addition to noise, other forms of interference found in radio receivers include the image frequency, transmitters operating on an adjacent channel and those using the same channel. The first form will be discussed in Section 6-2.1, and the other two are discussed here.

Adjacent-channel interference: Noise and Frequency Modulation offers not only an improvement in the S/N ratio but also better discrimination against other interfering signals, no matter what their source. It was seen in the preceding section that FM having a maximum deviation of 75 kHz and 75- μ s pre-emphasis gives a noise rejection at least 24 dB better than AM. Thus, if an AM receiver requires an S/N ratio of 60 dB at the detector for almost perfect reception, the FM receiver will give equal performance for a ratio no better than 36 dB. This is regardless of whether the interfering signal is due to noise or signals being admitted from an adjacent channel. The mechanism whereby the FM limiter reduces interference is precisely the same as that used to deal with random noise.

One more factor should be included in this discussion of adjacent-channel interference. When FM broadcasting systems began, AM systems had been in operation for nearly 30 years, a lot of experience with broadcasting systems had been obtained, and planners could profit from earlier mistakes. Thus, as already mentioned, each wideband FM broadcasting channel occupies 200 kHz (of which only 180 kHz is used), and the remaining 20-kHz guard band goes a long way toward reducing adjacent channel interference even further.

Cochannel interference-capture effect: The amplitude limiter works on the principle of passing the stronger signal and eliminating the weaker. This was the reason for mentioning earlier that noise reduction is obtained only when the signal is at least twice the noise peak amplitude. A relatively weak interfering signal from another transmitter will also be attenuated in this manner, as much as any other form of interference. This applies even if the other transmitter operates on the same frequency as the desired transmitter.

In mobile receivers, travelling from one transmitter toward another (cochannel) one, the interesting phenomenon of capture occurs. However, it must first be mentioned that the effect would be very straightforward with AM transmitters, The nearer transmitter would always predominate, but the other one would be heard as quite significant interference although it might be very distant.

The situation is far more interesting with FM. Until the signal from the second transmitter is less than about half of that from the first, the second transmitter is virtually inaudible, causing practically no interference. After this point, the transmitter toward which the receiver is

moving becomes quite audible as a background and eventually predominates, finally excluding the first transmitter. The moving receiver has been captured by the second transmitter. If a receiver is between the two transmitters (roughly in the center zone) and fading conditions prevail, first one signal, and then the other, will be the stronger. As a result, the receiver will be captured alternatively by either transmitter. This switching from one program to the other is most distracting, of course (once the initial novelty has worn off!), and would not happen in an AM system.

Comparison of Wideband and Narrowband FM:

By convention, wideband FM has been defined as that in which the modulation index normally exceeds unity. This is the type so far discussed. Since the maximum permissible deviation is 75 kHz and modulating frequencies range from 30 Hz to 15 kHz, the maximum modulation index ranges from 5 to 2500. (The maximum permissible deviation for the sound accompanying TV transmissions is 25 kHz in the United States' NTSC system and 50 kHz in the PAL system used in Europe and Australia. Both are wideband systems.) The modulation index in narrowband FM is near unity, since the maximum modulating frequency there is usually 3 kHz, and the maximum deviation is typically 5 kHz.

The proper bandwidth to use in an FM system depends on the application. With a large deviation, noise will be better suppressed (as will other interference), but care must be taken to ensure that impulse noise peaks do not become excessive. On the other hand, the wideband system will occupy up to 15 times the bandwidth of the narrowband system. These considerations have resulted in wideband systems being used in entertainment broadcasting, while narrowband systems are employed for communications.

Thus narrowband FM is used by the so-called FM mobile communications services. These include police, ambulances, taxicabs, radio-controlled appliance repair services, short-range VHF ship-to-shore services and the Australian "Flying Doctor" service. The higher audio frequencies are attenuated, as indeed they are in most carrier (long-distance) telephone systems, but the resulting speech quality is still perfectly adequate. Maximum deviations of 5 to 10 kHz are permitted, and the channel space is not much greater than for AM broadcasting, i.e., of the order of 15 to 30 kHz. Narrowband systems with even lower maximum deviations are envisaged. Pre-emphasis and de-emphasis are used, as indeed they are with all FM transmissions.

AM Transmitters

Transmitters that transmit AM signals are known as AM transmitters. These transmitters are used in medium wave (MW) and short wave (SW) frequency bands for AM broadcast. The MW band has frequencies between 550 KHz and 1650 KHz, and the SW band has frequencies ranging from 3 MHz to 30 MHz. The two types of AM transmitters that are used based on their transmitting powers are:

- High Level
- Low Level

High level transmitters use high level modulation, and low level transmitters use low level modulation. The choice between the two modulation schemes depends on the transmitting power of the AM transmitter. In broadcast transmitters, where the transmitting power may be of the order of kilowatts, high level modulation is employed. In low power transmitters, where only a few watts of transmitting power are required, low level modulation is used.

High-Level and Low-Level Transmitters

Below figure's show the block diagram of high-level and low-level transmitters. The basic difference between the two transmitters is the power amplification of the carrier and modulating signals.

Figure (a) shows the block diagram of high-level AM transmitter.

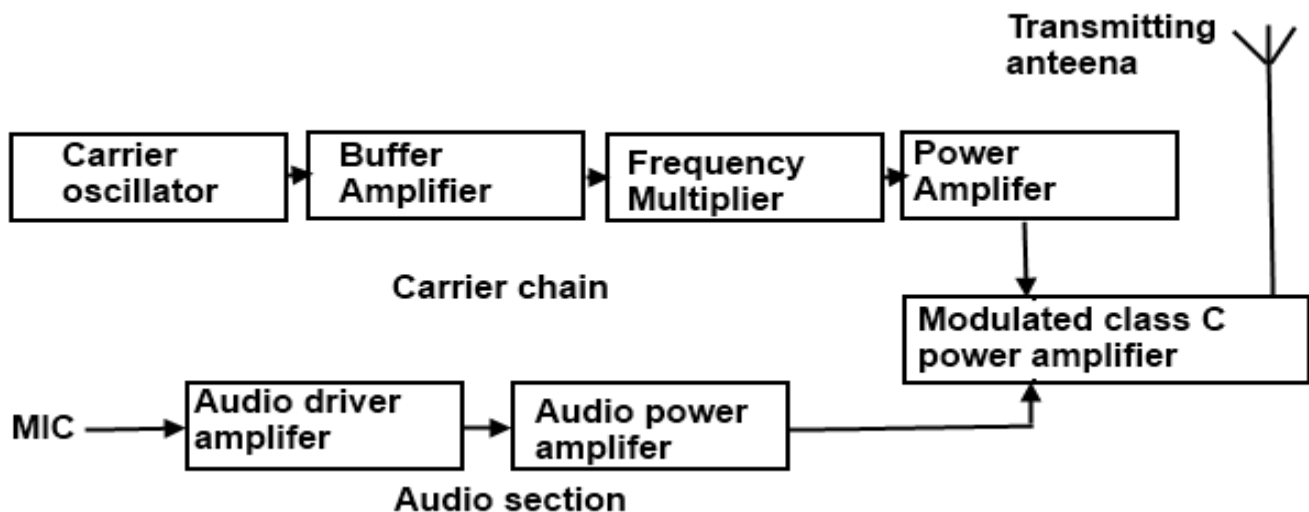

Figure (a): Block Diagram of High Level AM Transmitter

Figure (a) is drawn for audio transmission. In high-level transmission, the powers of the carrier and modulating signals are amplified before applying them to the modulator stage, as shown in

figure (a). In low-level modulation, the powers of the two input signals of the modulator stage are not amplified. The required transmitting power is obtained from the last stage of the transmitter, the class C power amplifier.

The various sections of the figure (a) are:

- Carrier oscillator
- Buffer amplifier
- Frequency multiplier
- Power amplifier
- Audio chain
- Modulated class C power amplifier

Carrier oscillator

The carrier oscillator generates the carrier signal, which lies in the RF range. The frequency of the carrier is always very high. Because it is very difficult to generate high frequencies with good frequency stability, the carrier oscillator generates a sub multiple with the required carrier frequency. This sub multiple frequency is multiplied by the frequency multiplier stage to get the required carrier frequency. Further, a crystal oscillator can be used in this stage to generate a low frequency carrier with the best frequency stability. The frequency multiplier stage then increases the frequency of the carrier to its required value.

Buffer Amplifier

The purpose of the buffer amplifier is two fold. It first matches the output impedance of the carrier oscillator with the input impedance of the frequency multiplier, the next stage of the carrier oscillator. It then isolates the carrier oscillator and frequency multiplier.

This is required so that the multiplier does not draw a large current from the carrier oscillator. If this occurs, the frequency of the carrier oscillator will not remain stable.

Frequency Multiplier

The sub-multiple frequency of the carrier signal, generated by the carrier oscillator, is now applied to the frequency multiplier through the buffer amplifier. This stage is also known as harmonic generator. The frequency multiplier generates higher harmonics of carrier oscillator frequency. The frequency multiplier is a tuned circuit that can be tuned to the requisite carrier frequency that is to be transmitted.

Power Amplifier

The power of the carrier signal is then amplified in the power amplifier stage. This is the basic requirement of a high-level transmitter. A class C power amplifier gives high power current pulses of the carrier signal at its output.

Audio Chain

The audio signal to be transmitted is obtained from the microphone, as shown in figure (a). The audio driver amplifier amplifies the voltage of this signal. This amplification is necessary to drive the audio power amplifier. Next, a class A or a class B power amplifier amplifies the power of the audio signal.

Modulated Class C Amplifier

This is the output stage of the transmitter. The modulating audio signal and the carrier signal, after power amplification, are applied to this modulating stage. The modulation takes place at this stage. The class C amplifier also amplifies the power of the AM signal to the required transmitting power. This signal is finally passed to the antenna, which radiates the signal into space of transmission.

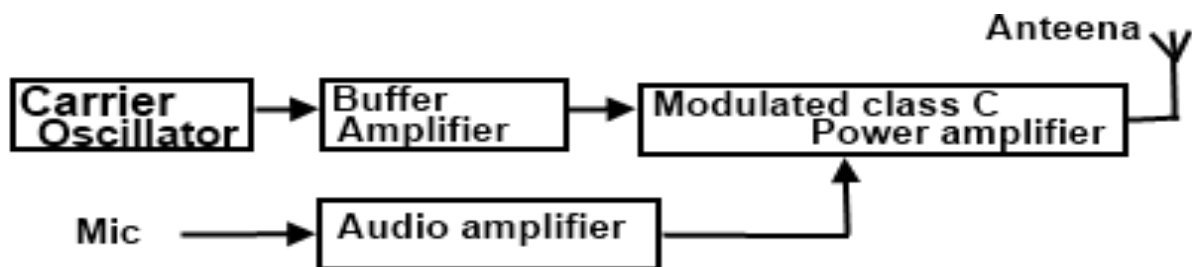

Figure (b): Block Diagram of Low Level AM Transmitter

The low-level AM transmitter shown in the figure (b) is similar to a high-level transmitter, except that the powers of the carrier and audio signals are not amplified. These two signals are directly applied to the modulated class C power amplifier.

Modulation takes place at the stage, and the power of the modulated signal is amplified to the required transmitting power level. The transmitting antenna then transmits the signal.

Coupling of Output Stage and Antenna

The output stage of the modulated class C power amplifier feeds the signal to the transmitting antenna. To transfer maximum power from the output stage to the antenna it is necessary that the impedance of the two sections match. For this, a matching network is required. The

matching between the two should be perfect at all transmitting frequencies. As the matching is required at different frequencies, inductors and capacitors offering different impedance at different frequencies are used in the matching networks.

The matching network must be constructed using these passive components. This is shown in below Figure (c).

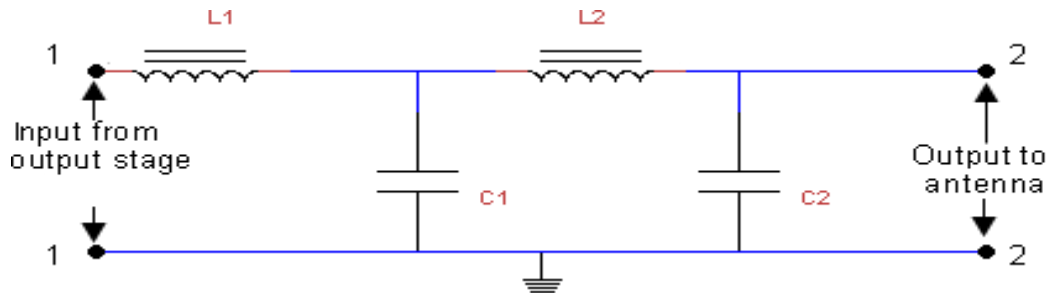

Figure (c): Double Pi Matching Network

The matching network used for coupling the output stage of the transmitter and the antenna is called double π -network. This network is shown in figure (c). It consists of two inductors, L_1 and L_2 and two capacitors, C_1 and C_2 . The values of these components are chosen such that the input impedance of the network between 1 and 1'. Shown in figure (c) is matched with the output impedance of the output stage of the transmitter. Further, the output impedance of the network is matched with the impedance of the antenna.

The double π matching network also filters unwanted frequency components appearing at the output of the last stage of the transmitter. The output of the modulated class C power amplifier may contain higher harmonics, such as second and third harmonics, that are highly undesirable. The frequency response of the matching network is set such that these unwanted higher harmonics are totally suppressed, and only the desired signal is coupled to the antenna.

Requirements of a Receiver

AM receiver receives AM wave and demodulates it by using the envelope detector. Similarly, FM receiver receives FM wave and demodulates it by using the Frequency Discrimination method. Following are the requirements of both AM and FM receiver.

- It should be cost-effective.
- It should receive the corresponding modulated waves.
- The receiver should be able to tune and amplify the desired station.
- It should have an ability to reject the unwanted stations.
- Demodulation has to be done to all the station signals, irrespective of the carrier signal frequency.

For these requirements to be fulfilled, the tuner circuit and the mixer circuit should be very effective. The procedure of RF mixing is an interesting phenomenon.

RF Mixing

The RF mixing unit develops an **Intermediate Frequency (IF)** to which any received signal is converted, so as to process the signal effectively.

RF Mixer is an important stage in the receiver. Two signals of different frequencies are taken where one signal level affects the level of the other signal, to produce the resultant mixed output. The input signals and the resultant mixer output is illustrated in the following figures.

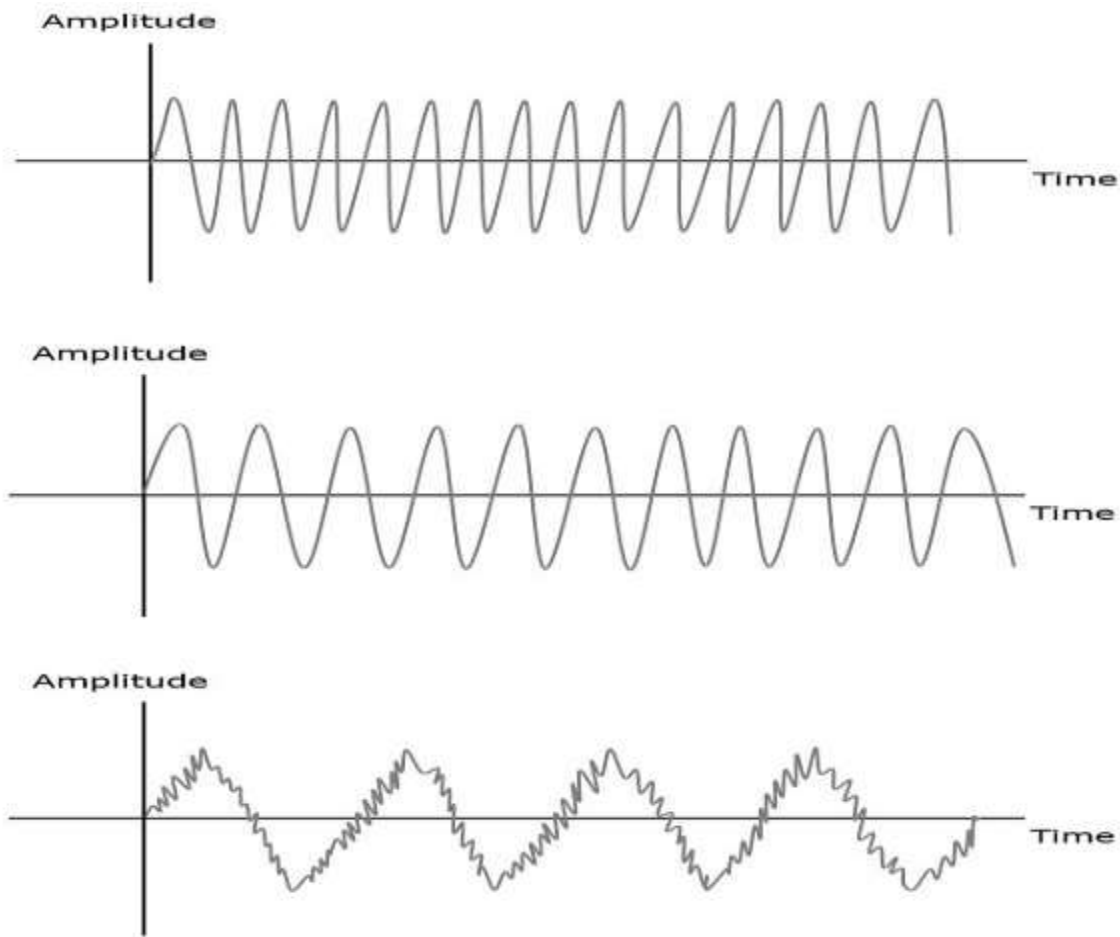

Let the first and second signal frequencies be f_1 and f_2 . If these two signals are applied as inputs of RF mixer, then it produces an output signal, having frequencies of f_1+f_2 and f_1-f_2 . If this is observed in the frequency domain, the pattern looks like the following figure.

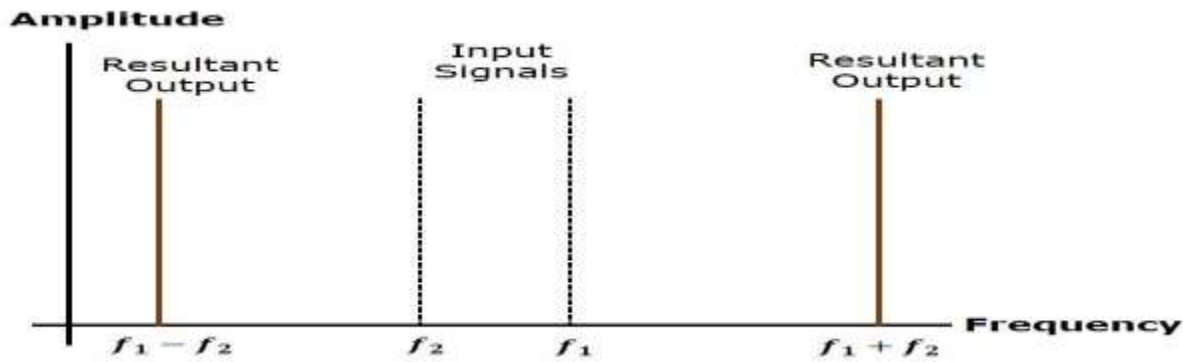

In this case, f_1 is greater than f_2 . So, the resultant output has frequencies f_1+f_2 and f_1-f_2 . Similarly, if f_2 is greater than f_1 , then the resultant output will have the frequencies f_1+f_2 and f_1-f_2

Superheterodyne AM Receiver

Radio amateurs are the initial radio receivers. However, they have drawbacks such as poor sensitivity and selectivity. To overcome these drawbacks, super heterodyne receiver was invented.

Selectivity is the ability of selecting a particular signal, while rejecting the others. **Sensitivity** is the capacity of detecting RF signal and demodulating it, while at the lowest power level.

The AM super heterodyne receiver takes the amplitude modulated wave as an input and produces the original audio signal as an output. In Superheterodyne radio receivers, the incoming radio signals are intercepted by the antenna and converted into the corresponding currents and voltages. In the receiver, the incoming signal frequency is mixed with a locally generated frequency. The output of the mixer consists of the sum and difference of the two frequencies. The mixing of the two frequencies is termed *heterodyning*. Out of the two resultant components of the mixer, the sum component is rejected and the difference component is selected. The value of the difference frequency component varies with the incoming frequencies, if the frequency of the local oscillator is kept constant. It is possible to keep the frequency of the difference components constant by varying the frequency of the local oscillator according to the incoming signal frequency. In this case, the process is called Superheterodyne and the receiver is known as a superheterodyne radio receiver.

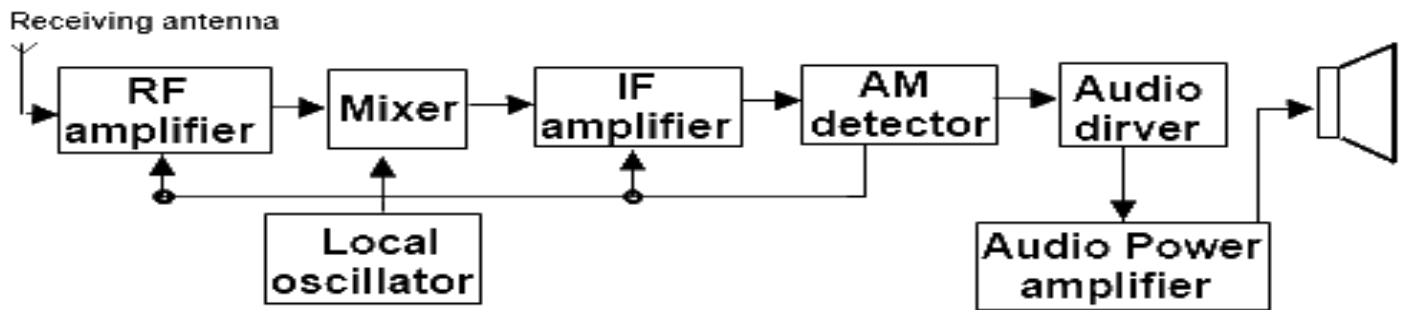

Superheterodyne AM Receiver Block Diagram

In Figure the receiving antenna intercepts the radio signals and feeds the RF amplifier, The RF amplifier selects the desired signal frequency and amplifies its voltage, The RF' amplifier is a small-signal voltage amplifier that operates in the RF range. This amplifier is tuned to the desired signal frequency by using capacitive tuning.

RF Mixer

After suitable amplification of the RF signal it is fed to the mixer. The mixer takes another input from a local oscillator, which generates a frequency according to the frequency of the selected signal so that the difference equals a predetermined value. The mixer consists of a non-linear device, such as a transistor. Due to the non-linearity, the mixer output consists of a number of frequency components. It provides sum and difference frequency components along with their higher harmonics. A tuned circuit at the output of the mixer selects only the difference component while rejecting all other components. The difference component is called the intermediate frequency or IF the value of IF frequency is always constant and is equal to 455 KHz.

IF Amplifier

For a constant IF frequency for all incoming signals, the frequency of the local oscillator is adjusted using capacitive tuning. The incoming signal is also selected using capacitive tuning. The two capacitors used to select the incoming signal and the oscillator frequency is ganged together so that the tuning of both the RF amplifier and the local oscillator circuits is done simultaneously. This arrangement ensures that the local oscillator has the correct frequency to generate constant IF frequencies. The mixer stage is also tuned to IF frequency using capacitive tuning. The tuning capacitor is also ganged with the RF amplifier and the local oscillator. Thus all the three stages are tuned at the same time to the required frequency through the ganged Capacitor, which consists of the three tuning capacitors.

The IF signal is fed to an IF amplifier with two amplifier stages. This provides enough signal amplification so that the signal is properly detected.

AM Demodulator

The amplified IF signal is fed to the linear diode detector, which demodulates the received AM signal. The output of the detector stage is the original modulating signal.

Audio Amplifier

This signal is given to the audio driver stage, which amplifies its voltage to drive the power amplifier, which is the last stage of the receiver.

The power of the modulating signal and finally is passed to the power amplifier amplifies the speaker. The speaker converts the audio currents into sound energy.

FM Transmitter

FM transmitter is the whole unit, which takes the audio signal as an input and delivers FM wave to the antenna as an output to be transmitted. The block diagram of FM transmitter is shown in the following figure.

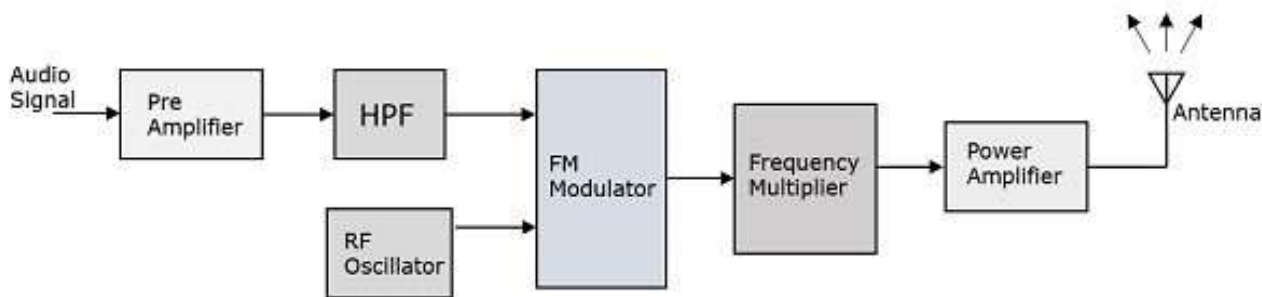

The working of FM transmitter can be explained as follows.

- The audio signal from the output of the microphone is sent to the pre-amplifier, which boosts the level of the modulating signal.
- This signal is then passed to high pass filter, which acts as a pre-emphasis network to filter out the noise and improve the signal to noise ratio.
- This signal is further passed to the FM modulator circuit.
- The oscillator circuit generates a high frequency carrier, which is sent to the modulator along with the modulating signal.

- Several stages of frequency multiplier are used to increase the operating frequency. Even then, the power of the signal is not enough to transmit. Hence, a RF power amplifier is used at the end to increase the power of the modulated signal. This FM modulated output is finally passed to the antenna to be transmitted.

FM Receiver

The block diagram of FM receiver is shown in the following figure.

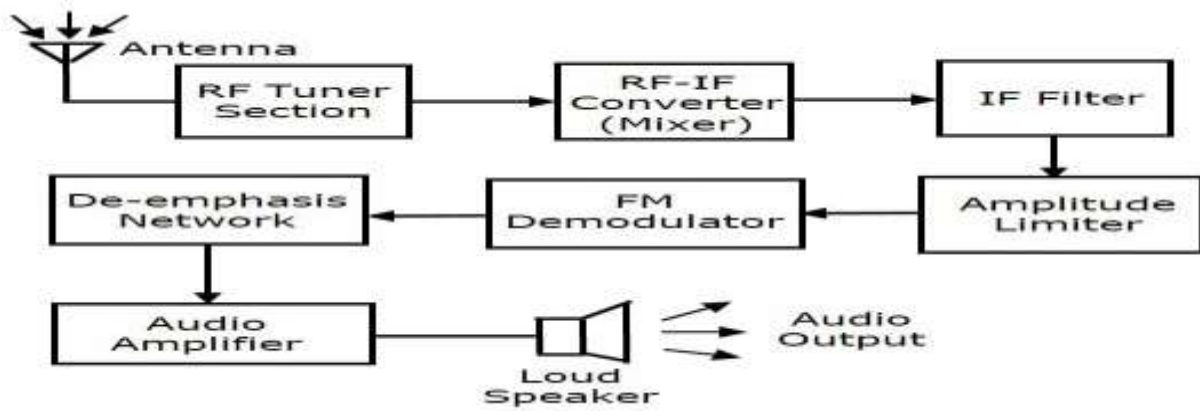

This block diagram of FM receiver is similar to the block diagram of AM receiver. The two blocks Amplitude limiter and De-emphasis network are included before and after FM demodulator. The operation of the remaining blocks is the same as that of AM receiver.

We know that in FM modulation, the amplitude of FM wave remains constant. However, if some noise is added with FM wave in the channel, due to that the amplitude of FM wave may vary. Thus, with the help of amplitude limiter we can maintain the amplitude of FM wave as constant by removing the unwanted peaks of the noise signal.

In FM transmitter, we have seen the pre-emphasis network (High pass filter), which is present before FM modulator. This is used to improve the SNR of high frequency audio signal. The reverse process of pre-emphasis is known as de-emphasis. Thus, in this FM receiver, the de-emphasis network (Low pass filter) is included after FM demodulator. This signal is passed to the audio amplifier to increase the power level. Finally, we get the original sound signal from the loudspeaker.

Superheterodyne FM Receiver

The block diagram of an FM receiver is illustrated in Figure (a). The RF amplifier amplifies the received signal intercepted by the antenna. The amplified signal is then applied to the mixer

stage. The second input of the mixer comes from the local oscillator. The two input frequencies of the mixer generate an IF signal of 10.7 MHz. This signal is then amplified by the IF amplifier. Figure (a) shows the block diagram of an FM receiver.

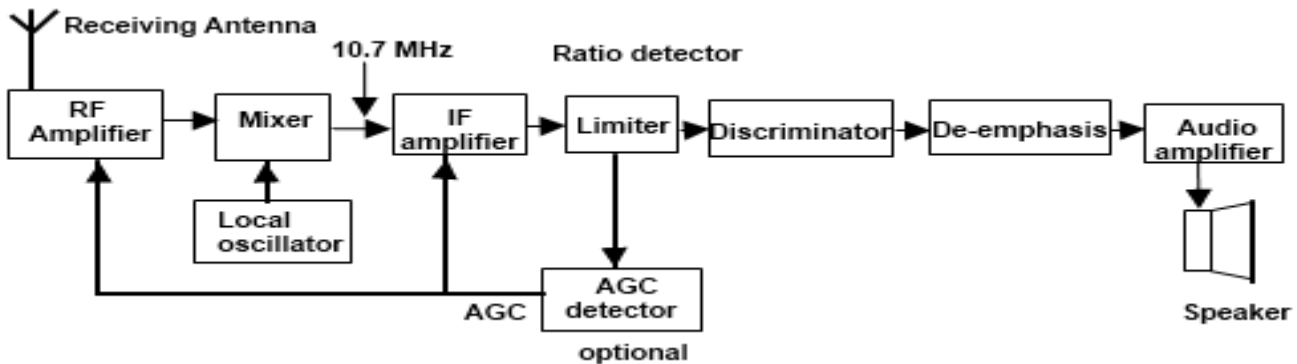

Superheterodyne FM Receiver Block Diagram

The output of the IF amplifier is applied to the limiter circuit. The limiter removes the noise in the received signal and gives a constant amplitude signal. This circuit is required when a phase discriminator is used to demodulate an FM signal.

The output of the limiter is now applied to the FM discriminator, which recovers the modulating signal. However, this signal is still not the original modulating signal. Before applying it to the audio amplifier stages, it is de-emphasized. De-emphasizing attenuates the higher frequencies to bring them back to their original amplitudes as these are boosted or emphasized before transmission. The output of the de-emphasized stage is the audio signal, which is then applied to the audio stages and finally to the speaker. It should be noted that a limiter circuit is required with the FM discriminators. If the demodulator stage uses a ratio detector instead of the discriminator, then a limiter is not required. This is because the ratio detector limits the amplitude of the received signal. In Figure (a) a dotted block that covers the limiter and the discriminator is marked as the ratio detector.

In FM receivers, generally, AGC is not required because the amplitude of the carrier is kept constant by the limiter circuit. Therefore, the input to the audio stages controls amplitudes and there are no erratic changes the volume level. However, AGC may be provided using an AGC detector. This generates a dc voltage to control the gains of the RF and IF amplifier.

RF Amplifier Using FET

The RF amplifier in FM receivers uses FETs as the amplifying device. A bipolar junction transistor can also be used for the purpose, but an FET has certain advantages over BJT. These are explained below:

- An FET follows the square law for its operation, the characteristics; curves of an FET have non-linear regions. Due to the non-linearity, higher harmonics of the signal frequency are generated in the output. The major advantage of an FET is that it generates only the second harmonic components of the signal. This is known as the square law. Harmonics higher than the second harmonic is nearly absent in the output of an FET amplifier. The higher harmonics produce harmonic distortions and are undesirable. In FETs, as only the second harmonics are present; it is easy to filter these out by using the tuned circuits. BJTs also generate higher harmonics, but they do not follow the square law. Therefore, they provide more harmonic distortion than FETs. Thus, FETs are always preferred in the RF amplifier of an FM receiver.
- In BJT amplifiers, cross-modulation occurs if a strong signal of an adjacent channel gets through the tuned circuits in the presence of a weak desired signal. The adjacent channel will generate higher harmonics, which may come within the pass-band of the desired signal. This will produce noise and distortions at the output. On the other hand, The effect of cross-modulation is minimized in FET amplifiers, as the unwanted adjacent channel will also produce only its second harmonic components, which may not fall into the pass-band of the desired channel and thus are easily filtered out.
- The input impedance of an FET becomes small due to the small input capacitive reactance of FET at very high FM frequencies. This makes it easy to match the small impedance of the antenna, typically 100 ohms, with the small input impedance of FET. This is not possible with BJTs.

Limiter Circuit

Limiter circuit is used in FM receiver to remove the noise present in the peaks of the received signal and to remove any amplitude variation in the received signal; the output of the limiter has constant amplitude. This is very important in FM receivers because at amplitude variation in the received carrier will result in unfaithful reproduction of the audio signals. Figure (b) shows the typical circuit diagram of a limiter circuit used in an FM receiver.

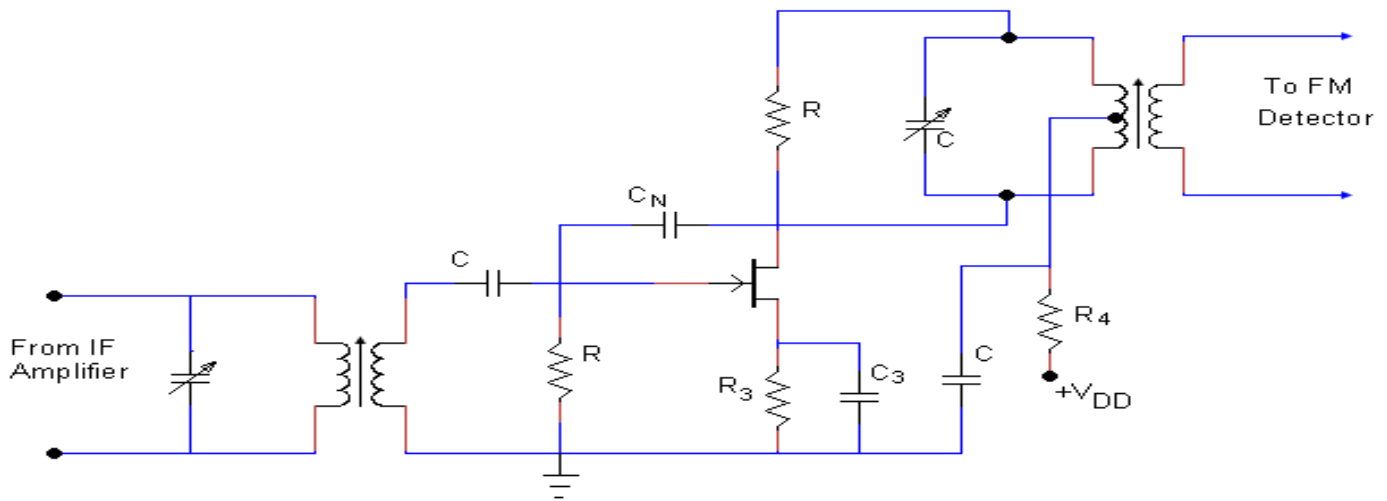

Limiter Circuit Used in FM Transmitter

A typical circuit diagram of a limiter using FET is illustrated in figure (b). This circuit has a leak-type bias at the gate, through R and C . The source resistance is R_S and the source bypass capacitor is C . The capacitor C_N provides the neutralization of the signal passing through the internal capacitance between the gate and the drain. The limiting action is provided by the gate and drain circuits.

Gate Limiting Action

If the input voltage increases, then the gate bias of an FET accordingly increases. The increase in the negative bias at the gate will reduce the gain of the amplifier. This will reduce the output of the circuit so a constant amplitude signal will be applied to the discriminator. It should be noted that for small input voltages, the limiting action will not take place as there will be no appreciable change in the gate biasing voltage. The limiting action only takes place for large input signals.

Drain Limiting Action

The limiting action for low amplitude variations is achieved by using the drain circuit. The drain DC supply is kept at half the normal DC drain voltage through the dropping resistance R_d . With this arrangement, low input voltages result in the saturation of the output current. This action limits the amplitude of the output signal. Under this condition, it may be possible that the gate-drain section forward-biased. If this happens, then the input and output will be short-circuited. To avoid this undesirable situation, a small resistance of a few hundred ohms, R , is placed in between the drain and the tank circuit, as shown in figure (a).